

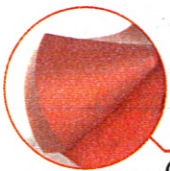

The Deburring Expert!

90° Three flute countersinks ANTI VIBRATION

ANTI VIBRATION géométrie =
unequalled finish



Constant profil relief =
great many regrinds

Grooves opened wide =
allows strong chips a way out

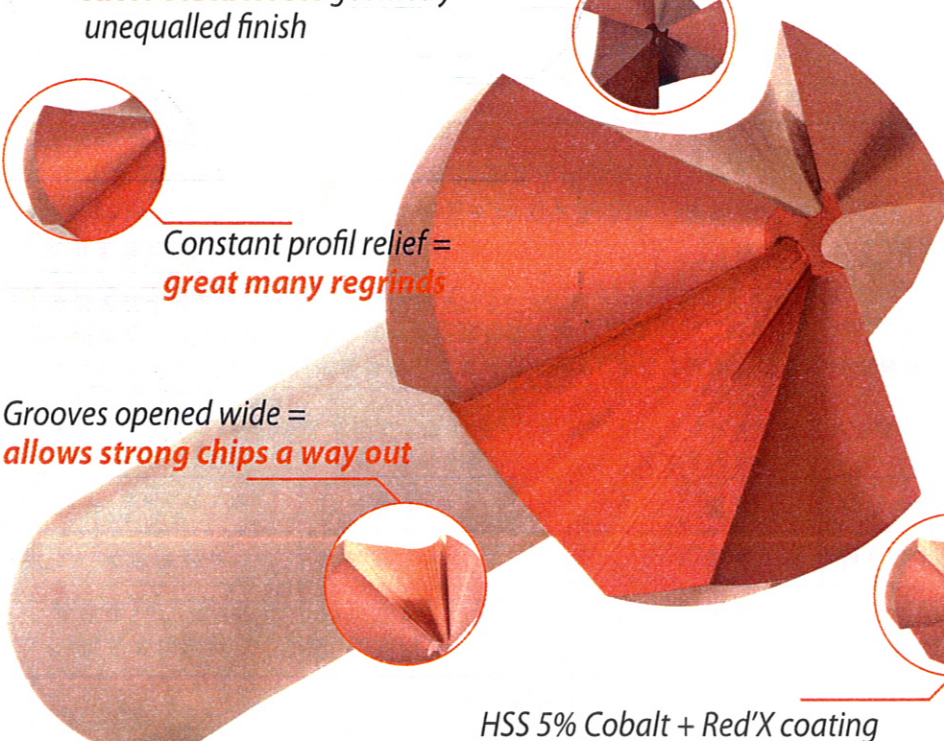
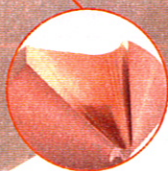

HSS 5% Cobalt + Red'X coating
3500 HV = **improved performances**

Standard

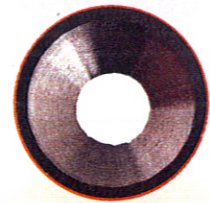

ANTI VIBRATION



Competitor

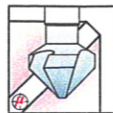
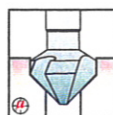
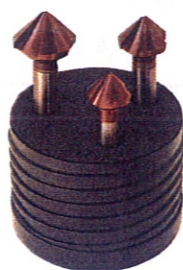
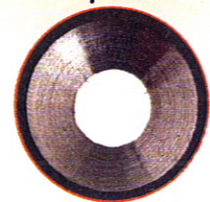

quality: HSS 5% Co + **Red-X**

Set of 3 tools	Code	Price	Expert price
Ø 8,3 - 12,4 - 20,5	493A/98	109,35€	
Ø 10,4 - 16,5 - 25	493A/99	219,70€	

TRI-DENT

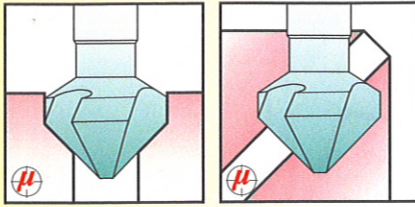

90° Three flute COUNTERSINKS ANTI VIBRATIONS

The equal division 3 x 120° of the flutes offers good results in most materials. For iron alloys vibrations may happen and generate facets. These new ANTI VIBRATION countersinks with unequal division of the flutes avoid this phenomenon. For machining of the copper and light materials (aluminium, plastics) we recommend the use of the deburring tool with hole page 56 - 57.

90° Tres labios AVELLANADORES ANTI VIBRACIONES

La distribución simétrica de los labios 3 x 120° ofrecen buenos resultados en la mayoría de materiales. En aleaciones férricas pueden haber vibraciones que generan facetas. Estos nuevos avellanadores anti-vibración con paso diferencial evitan este fenómeno. Para el mecanizado de cobre y materiales ligeros (aluminios, plásticos) recomendamos el uso de herramientas de desbarbar con agujero. Páginas 56-57.

90° 三 刃 鉸孔 防震

提供相同等級的3×120°的刃長在大多數材料上都適合使用對於鐵合金，可能會發生振動生成小平面。這些新的防震鉸孔鉗有不平等的刃長等級可避免了這現象產生為了加工銅和輕質材料（鋁，塑料），我們建議使用第56-57頁中的孔去毛刺工具。

New 2017

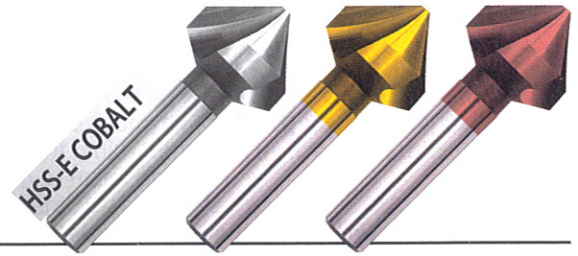

90°

DIN 335 - C

D	d1	d2	L	magafor	TiN	Red'X
z9	maxi	h9	± 1	43-A	483-A	493-A
4,3	1,3	4	40	€ .	€ .	€ .
5,3	1,5	4	40
6,0	1,5	5	45
6,3	1,5	5	45
8,0	2,0	6	50
8,3	2,0	6	50
9,4	2,2	6	50
10,0	2,5	6	50
10,4	2,5	6	50
11,5	2,8	8	56
12,0	2,8	8	56
12,4	2,8	8	56
15,0	3,2	10	60
16,5	3,2	10	60
20,5	3,5	10	63
25,0	3,8	10	67
28,0	4,0	12	71
30,0	4,2	12	71
31,0	4,2	12	71

No more vibrations = unequalled finish!
No más vibraciones = ¡acabados inigualables!
沒有更多的振動 = 無與倫比的加工!

performances

Page 頁
Página 70

New 2017

For precise and performance drilling, three ranges of micro-drills (3xD - 5xD - 8xD) are offered.

The range 5 x D is stocked in 0,01 mm increments from 0,10 to 3,00 mm.

The micro-drills for pre drilling ensure a precise location and perfectly aligned holes. Select the first smaller diameter d1, than the drill diameter.

Para un taladrado preciso y eficiente, disponemos de tres rangos de micro broca (3xD - 5xD - 8xD).

La gama 5xD está disponible en stock en incrementos de 0,01 mm desde 0,10 a 3,00 mm. Las micro brocas para pretaladrado garantizan precisión y proporciona agujeros completamente concéntricos. Seleccione el diámetro d1 inmediatamente inferior al taladrado a realizar.

針對於精密表現鉗孔加工，微型鉗頭有3種規格 (3xD - 5xD - 8xD) 提供

5xD的微型鉗頭規格是由0.1 到 3.0mm的，每規格是0.01mm的增加
該微型鑽頭用於鑽探嚴格位置和在線孔，請選擇最小直徑D1的

**PRE-DRILLING
MICRO DRILLS**

**PRETALADRADO
MICRO BROCAS**

**預備鉗孔加工
微細鉗頭**

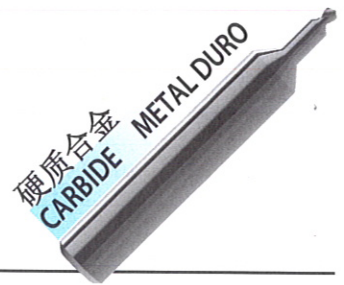
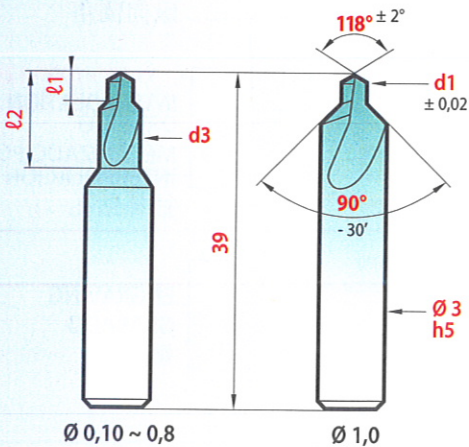
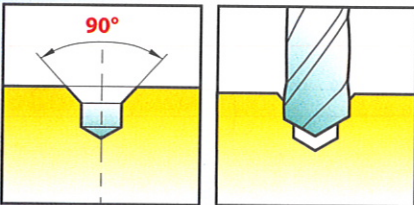

90°

d1	d3 mini	l1 mini	l2	magaforce 82X1
0,10	0,55	0,10	1,8	€ •
0,15	0,55	0,15	1,8	•
0,20	0,55	0,20	1,8	•
0,25	0,85	0,25	2,7	•
0,30	0,85	0,30	2,7	•
0,40	1,4	0,40	4,5	•
0,50	1,4	0,50	4,5	•
0,60	2,3	0,60	7,2	•
0,80	2,3	0,80	7,2	•
1,00	-	1,00	-	•

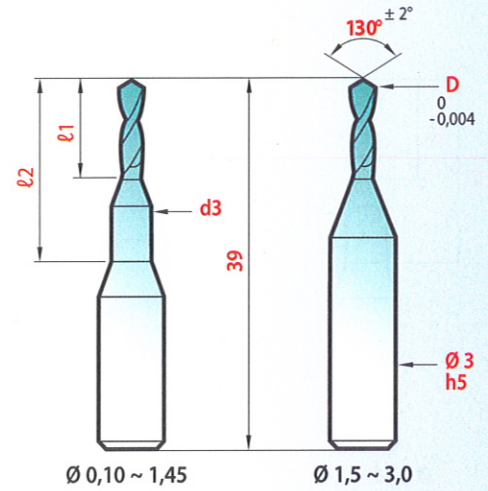
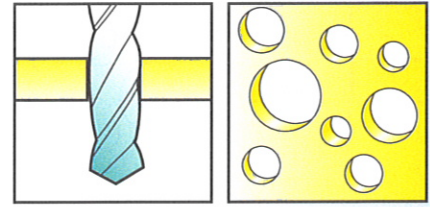
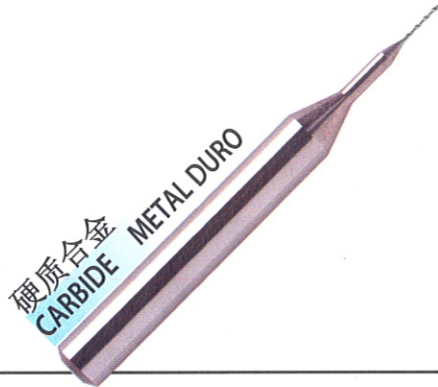

3 x D MICRO DRILLS
3 x D MICRO BROCAS
3 x D 微型鑽頭

D	d3	l1	l2	magaforce 82X3
0,05	± 0,01	mini		
0,10	1	0,30	3	€ •
0,15	1	0,45	3	•
0,20	1	0,60	3	•
0,25	1	0,75	3	•
0,30	1	0,90	3	•
0,35	1	1,05	3	•
0,40	1	1,20	3	•
0,45	1	1,35	3	•
0,50	1,5	1,50	6	•
0,55 - 0,60	1,5	1,80	6	•
0,65 - 0,70	1,5	2,10	6	•
0,75 - 0,80	1,5	2,40	6	•
0,85 - 0,90	1,5	2,70	6	•
0,95 - 1,00	1,5	3,00	6	•
1,05 - 1,10	2	3,30	6	•
1,15 - 1,20	2	3,60	6	•
1,25 - 1,30	2	3,90	6	•
1,35 - 1,40	2	4,20	6	•
1,45	2	4,50	6	•
1,50	-	4,50	-	•
1,55 - 1,60	-	4,80	-	•
1,65 - 1,70	-	5,10	-	•
1,75 - 1,80	-	5,40	-	•
1,85 - 1,90	-	5,70	-	•
1,95 - 2,00	-	6,00	-	•
2,05 - 2,10	-	6,30	-	•
2,15 - 2,20	-	6,60	-	•
2,25 - 2,30	-	6,90	-	•
2,35 - 2,40	-	7,20	-	•
2,45 - 2,50	-	7,50	-	•
2,55 - 2,60	-	7,80	-	•
2,65 - 2,70	-	8,10	-	•
2,75 - 2,80	-	8,40	-	•
2,85 - 2,90	-	8,70	-	•
2,95 - 3,00	-	9,00	-	•

Sizes by 0,01 mm increment, please enquire.

Medidas con incremento de 0,01, rogamos consulta.

規格是每0.01的增長，請選擇

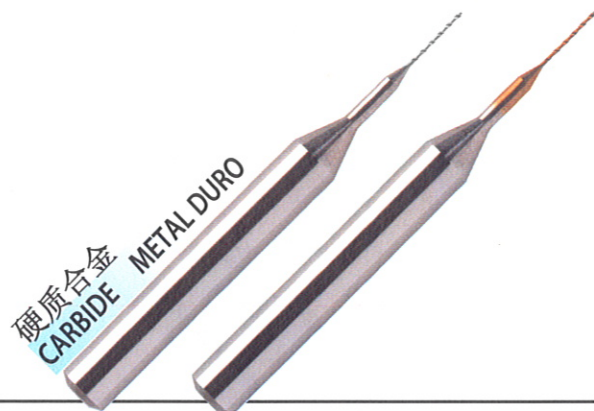
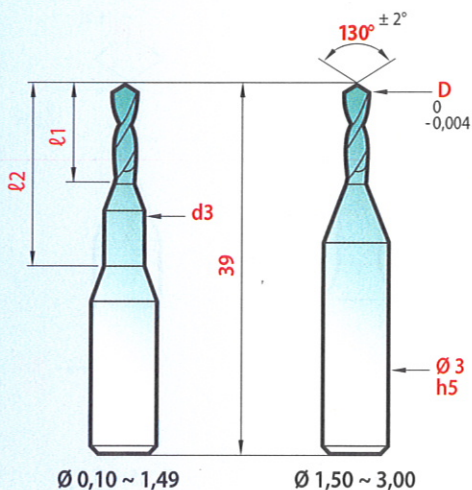
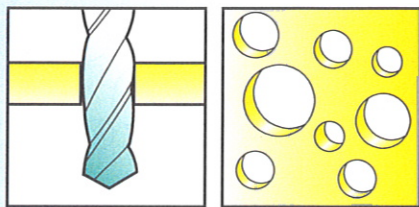

MICRO DRILLS 5xD MICRO BROCAS 5xD 微型鑽頭 5xD

Hard-X

With a high hardness (3500 HV), this coating shows a high thermic stability and an excellent protection against heat and wear. Ideal for dry machining - high speed cut - in treated steels and dies up to 67 HRC.

Con alta dureza (3500 HV) este recubrimiento presenta una gran estabilidad térmica y una excelente protección contra el calor y el desgaste. Ideal para el mecanizado en seco a alta velocidad en aceros de moldes y matrices. **Hasta 67 HRC.**

具有高的硬度(3500 HV), 塗層具有很高的耐熱穩定性和出色的防熱和磨損。非常適用於干式加工 - 高速切削 - 在處理鋼和模具可達 67 HRC

D	D*	d3	l1	l2	magaforce 82X5	Hard'X 82X5-H
0,01	0,05	± 0,01	mini		€ •	€ •
0,10	0,10	1	0,50	5	•	•
0,11 - 0,12		1	0,60	5	•	•
0,13 - 0,14		1	0,70	5	•	•
0,15 - 0,16	0,15	1	0,80	5	•	•
0,17 - 0,18		1	0,90	5	•	•
0,19 - 0,20	0,20	1	1,00	5	•	•
0,21 ~ 0,25		1	1,25	5	•	•
0,26 ~ 0,30	0,30	1	1,50	5	•	•
0,31 ~ 0,35	0,35	1	1,75	5	•	•
0,36 ~ 0,40	0,40	1	2,00	5	•	•
0,41 ~ 0,45	0,45	1	2,25	5	•	•
0,46 ~ 0,49		1	2,50	5	•	•
0,50	0,50	1,5	2,50	10	•	•
0,51 ~ 0,60	0,55 - 0,60	1,5	3,00	10	•	•
0,61 ~ 0,70	0,65 - 0,65	1,5	3,50	10	•	•
0,71 ~ 0,80	0,75 - 0,80	1,5	4,00	10	•	•
0,81 ~ 0,90	0,85 - 0,90	1,5	4,50	10	•	•
0,91 ~ 0,99	0,95	1,5	5,00	10	•	•
1,00	1,00	2	5,00	10	•	•
1,01 ~ 1,10	1,05 - 1,10	2	5,50	10	•	•
1,11 ~ 1,20	1,15 - 1,20	2	6,00	10	•	•
1,21 ~ 1,30	1,25 - 1,30	2	6,50	10	•	•
1,31 ~ 1,40	1,35 - 1,40	2	7,00	10	•	•
1,41 ~ 1,49	1,45	2	7,50	10	•	•
1,50	1,50	-	7,50	-	•	•
1,51 ~ 1,60	1,55 - 1,60	-	8,00	-	•	•
1,61 ~ 1,70	1,65 - 1,70	-	8,50	-	•	•
1,71 ~ 1,80	1,75 - 1,80	-	9,00	-	•	•
1,81 ~ 1,90	1,85 - 1,90	-	9,50	-	•	•
1,91 ~ 2,00	1,95 - 2,00	-	10,00	-	•	•
2,01 ~ 2,10	2,05 - 2,10	-	10,50	-	•	•
2,11 ~ 2,20	2,15 - 2,20	-	11,00	-	•	•
2,21 ~ 2,30	2,25 - 2,30	-	11,50	-	•	•
2,31 ~ 2,40	2,35 - 2,40	-	12,00	-	•	•
2,41 ~ 2,50	2,45 - 2,50	-	12,50	-	•	•
2,51 ~ 2,60	2,55 - 2,60	-	13,00	-	•	•
2,61 ~ 2,70	2,65 - 2,70	-	13,50	-	•	•
2,71 ~ 2,80	2,75 - 2,80	-	14,00	-	•	•
2,81 ~ 2,90	2,85 - 2,90	-	14,50	-	•	•
2,91 ~ 3,00	2,95 - 3,00	-	15,00	-	•	•

* Coated sizes Medidas con recubrimiento 塗層規格

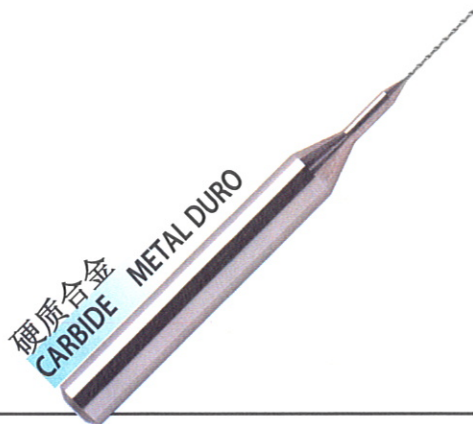

D	d3	ℓ1	ℓ2	magaforce 82X8
0,01	± 0,01	mini		
0,10	1	0,8	5	€ •
0,11 - 0,12	1	1,0	5	•
0,13 - 0,14	1	1,2	5	•
0,15 - 0,16	1	1,3	5	•
0,17 - 0,18	1	1,5	5	•
0,19	1	1,6	5	•
0,20	1	1,6	7	•
0,21 ~ 0,25	1	2,0	7	•
0,26 ~ 0,30	1	2,4	7	•
0,31 ~ 0,35	1	2,8	7	•
0,36 ~ 0,40	1	3,2	7	•
0,41 ~ 0,45	1	3,6	7	•
0,46 ~ 0,49	1	4,0	7	•
0,50	1	4,0	15	•
0,51 ~ 0,60	1	4,8	15	•
0,61 ~ 0,70	1,5	5,6	15	•
0,71 ~ 0,80	1,5	6,4	15	•
0,81 ~ 0,90	1,5	7,2	15	•
0,91 ~ 1,00	1,5	8,0	15	•
1,01 ~ 1,10	1,5	8,8	15	•
1,11 ~ 1,20	1,5	9,6	15	•
1,21 ~ 1,30	1,5	10,4	15	•
1,31 ~ 1,40	1,5	11,2	15	•
1,41 ~ 1,49	1,5	12,0	15	•
1,50	-	12,0	-	•
1,51 ~ 1,60	-	12,8	-	•
1,61 ~ 1,70	-	13,6	-	•
1,71 ~ 1,80	-	14,4	-	•
1,81 ~ 1,90	-	15,2	-	•
1,91 ~ 2,00	-	16,0	-	•
2,01 ~ 2,05	-	16,8	-	•

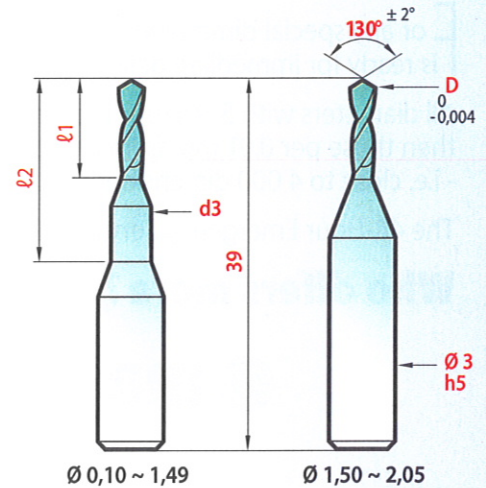

8xD MICRO DRILLS
8xD MICRO BROCAS
8xD 微型鑽頭

Hard-X

On request
 Bajo petición
 按需涂层



總代理
森雅貿易有限公司

新北市三重區重新路五段609巷4號6樓之10(湯城園區)
TEL: (02) 2999-7968 (代表號) FAX: (02) 2999-4822

E-mail: solidroc@ms76.hinet.net
web: http://www.solidrocktw.com

上海辦事處 TEL: 86-21-53014812、86-21-63040174

FAX: 86-21-53014872

facebook 請搜尋 森雅貿易有限公司

1 DUO-mag = 專利設計雙頭中心定位鑽

特殊 Red-X 強化鍍層
可加工硬度HRC55以上之材料

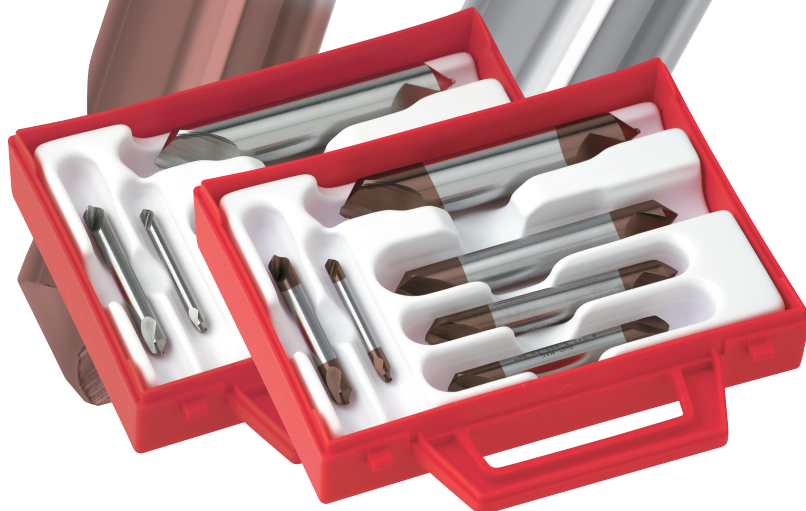

ANGLE	TYPE	COMPOSITION
60°	DUO-mag 016	Ø 3 - 4 - 6 8 - 10 - 12
	DUO-mag 0916	Ø 3 - 4 - 6 8 - 10 - 12
90°	DUO-mag 019	Ø 3 - 4 - 6 8 - 10 - 12
	DUO-mag 0919	Ø 3 - 4 - 6 8 - 10 - 12



提供您優惠的價格
 讓您享受最好的品質

Red-X

Up to 55 HRC

此鍍層具有3500HV硬度
 專為加工硬質合金所設計
 也可加工硬度高達55HRC以上之鋼材

90° 三刃倒角刀

HSS-E 5% 含鈷 + Red-X 特殊強化鍍層

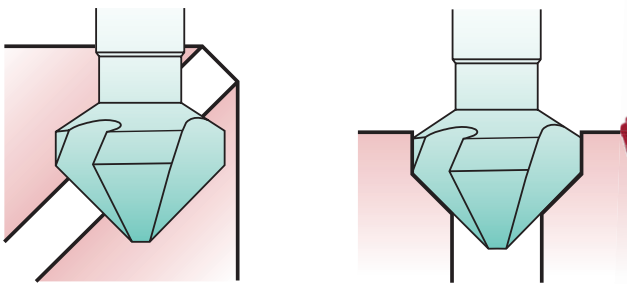

總代理
 森雅貿易有限公司

新北市三重區重新路五段609巷4號6樓之10(湯城園區)

TEL: (02) 2999-7968(代表號) FAX: (02) 2999-4822

E-mail: solidroc@ms76.hinet.net

web: http://www.solidrocktw.com

上海辦事處 TEL: 86-21-53014812、86-21-63040174

FAX: 86-21-53014872

facebook 請搜尋 森雅貿易有限公司

COMPOSITION	magafor
5 dimensions Ø10,4-16,5-20,5-25-31	4731
6 dimensions Ø6,3-8,3-10,4-12,4-16,5-20,5	4731/2

validity up to December, 31th, 2014